

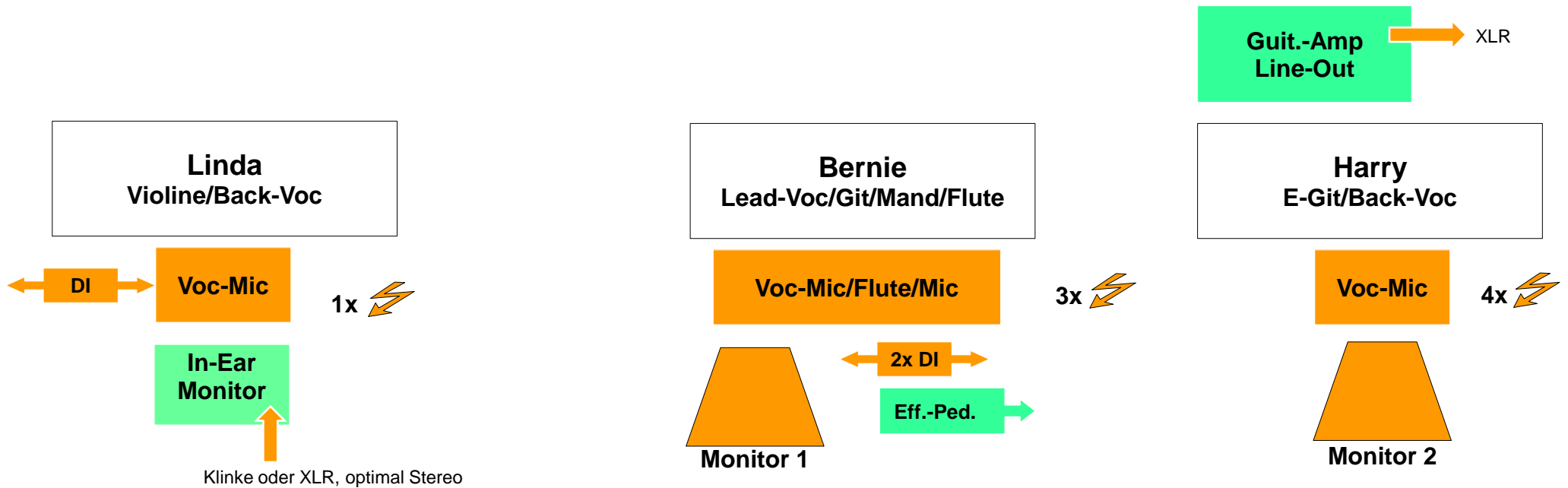

Technical Rider (Akustik-Drums full)

■ = Band ■ = Host ■ = optimum ⚡ = Power-supply

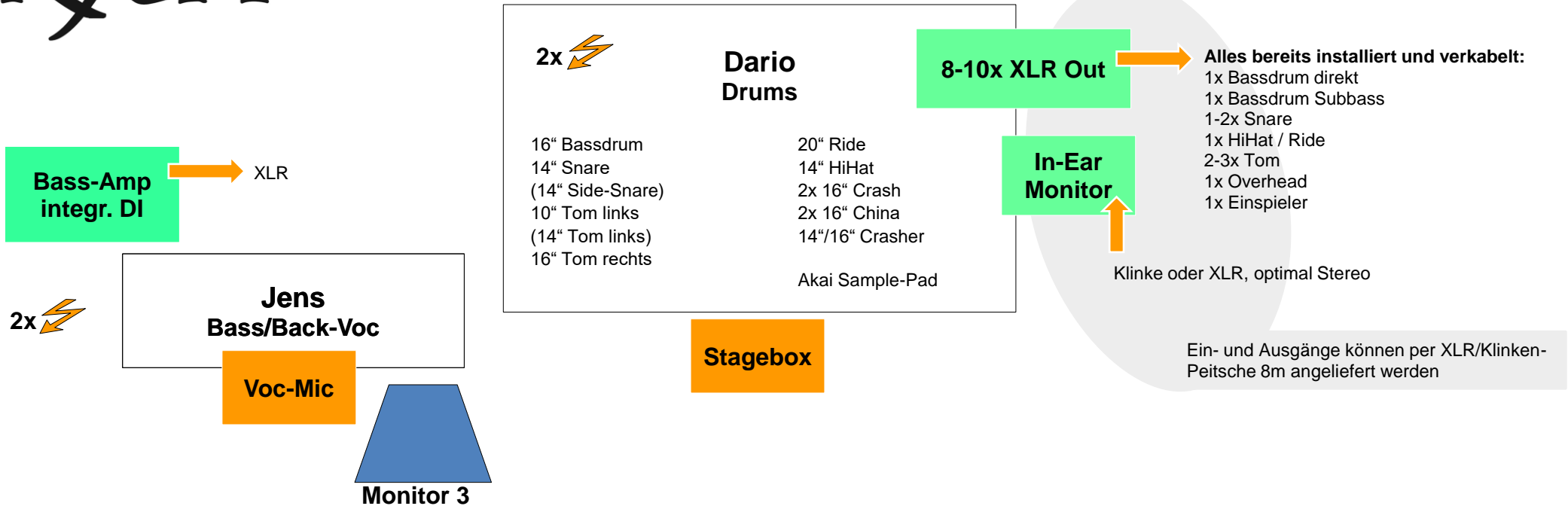



Technical Rider (Akustik-Drums small)

■ = Band ■ = Host ■ = optimum ⚡ = Power-supply

2x ⚡

Dario Drums

16" Bassdrum	20" Ride
14" Snare (14" Side-Snare)	14" HiHat
10" Tom links (14" Tom links)	2x 16" Crash
16" Tom rechts	2x 16" China
	14"/16" Crasher
	Akai Sample-Pad

3x XLR Out

Alles bereits installiert, gemischt und verkabelt:
1x Stereo-Out
1x Einspieler

In-Ear Monitor

Klinke oder XLR, optimal Stereo

Ein- und Ausgänge können per XLR/Klinken-Peitsche 8m angeliefert werden

Stagebox

Bass-Amp integr. DI

XLR

Jens Bass/Back-Voc

Voc-Mic

Monitor 3

2x ⚡

Linda Violine/Back-Voc

Voc-Mic

1x ⚡

In-Ear Monitor

Klinke oder XLR, optimal Stereo

Bernie Lead-Voc/Git/Mand/Flute

Voc-Mic/Flute/Mic

3x ⚡

Monitor 1

2x DI

Eff.-Ped.

Guit.-Amp Line-Out

XLR

Harry E-Git/Back-Voc

Voc-Mic

4x ⚡

Monitor 2



Technical Rider (E-Drums full)

■ = Band ■ = Host ■ = optimum ⚡ = Power-supply

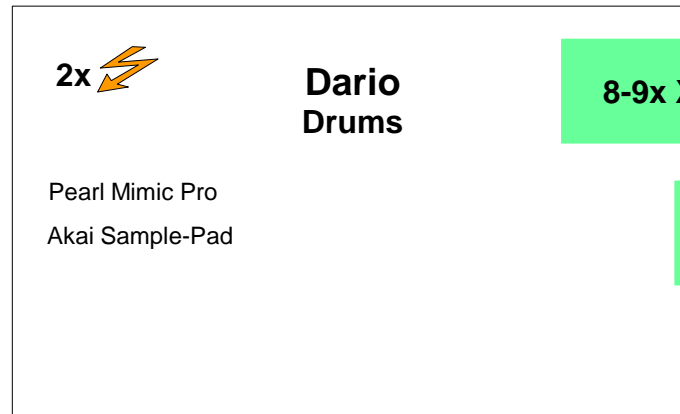

8-9x XLR Out

- 1x Bassdrum direkt
- 1x Snare
- 1x HiHat (/ Ride) (1x Ride)
- 2x Tom (Stereo-Feld)
- 2x Overhead
- 1x Einspieler

In-Ear Monitor

Klinke oder XLR, optimal Stereo

Ein- und Ausgänge können per XLR/Klinken-Peitsche 8m angeliefert werden

Stagebox

Bass-Amp integr. DI

XLR

Jens Bass/Back-Voc

2x ⚡

Voc-Mic

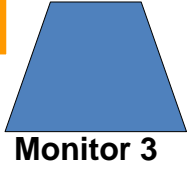

Monitor 3

Guit.-Amp Line-Out

XLR

Linda Violine/Back-Voc

Bernie Lead-Voc/Git/Mand/Flute

Harry E-Git/Back-Voc



In-Ear Monitor

Klinke oder XLR, optimal Stereo

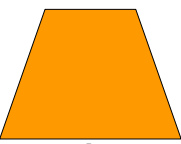
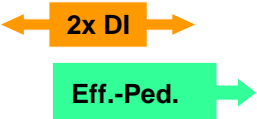

Monitor 1

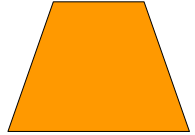

Monitor 2



Technical Rider (E-Drums small)

■ = Band ■ = Host ■ = optimum ⚡ = Power-supply

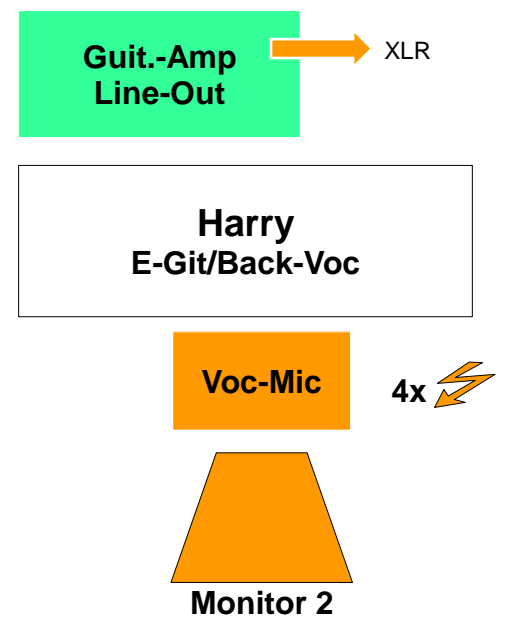
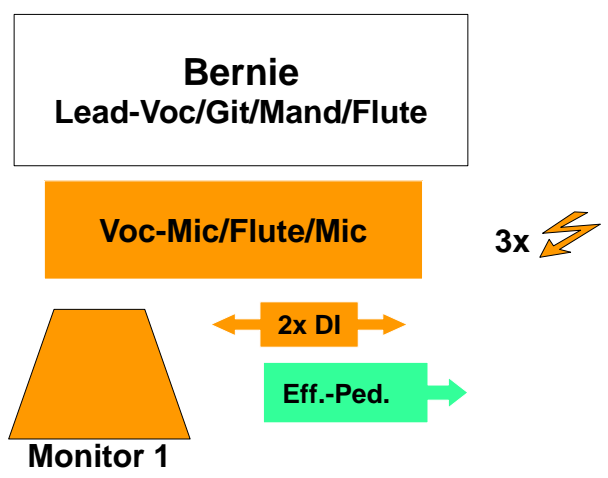
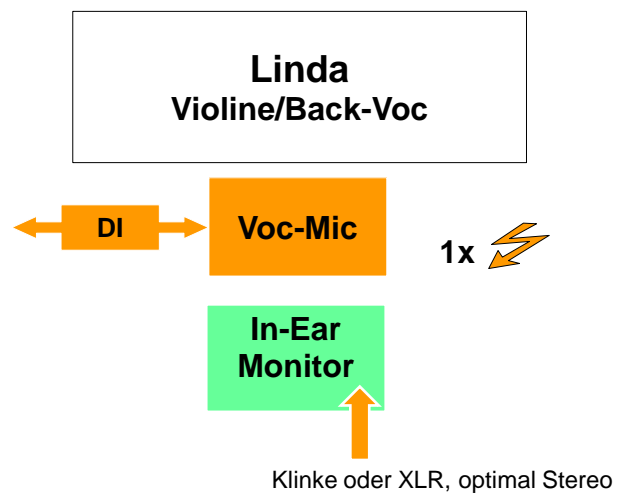
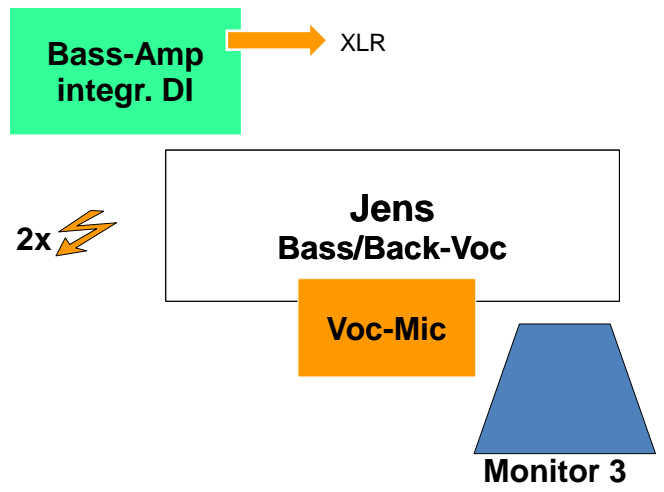
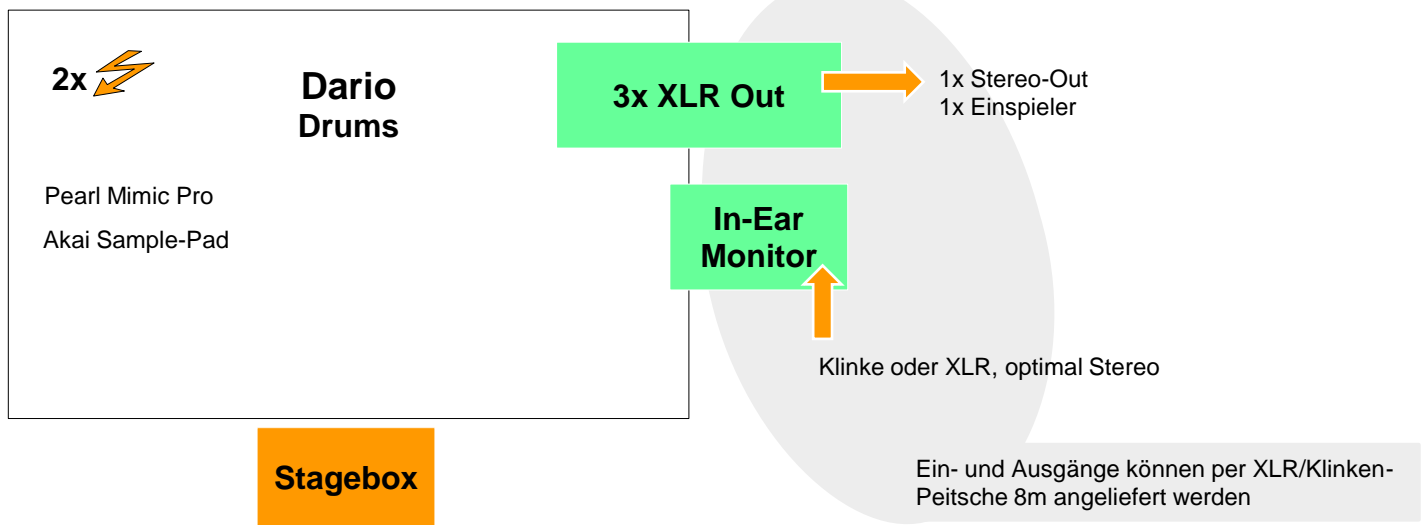



Technical Rider (Akustik-Drums full)

Max. channels – mixing console:

1. Lead Vocals (Bernie)
2. Background Vocals (Harry)
3. Background Vocals (Jens)
4. Background Vocals (Linda)
5. Acoustic Guitar
6. Mandoline
7. E-Guitar
8. Violine (Linda)
9. E-Bass
10. Kick Direkt
11. Kick Subbass
12. Snare 1
13. Snare 2
14. Tom links 1
15. Tom links 2
16. Tom rechts
17. Overhead
18. HiHat / Ride
19. Einspieler SamplePad

 Stereo Out

Techn. Contact:

Jens Ohly
jens_ohly@irxn.net
tel: +49 (0) 176 83056768

Vocals/Instruments/Backline:

- 4 x Vocals (2 x Lead, 2 x Background)
- 1 x Semi-Acoustic Guitar – Bernie
- 1 x Mandoline (acoustic with integrated Pickup) – Bernie
- 1 x Flute – Bernie
- 1 x Violine (acoustic with Pickup) - Linda
- 1 x E-Guitar - Harry
- 1 x E-Bass - Jens
- 1 x Drumset - Dario
- 1 x Guitar Combo 2x12 – Harry
- 1 x Multi-Effect Board - Harry
- 1 x Bass Amp (integrated DI) + Box - Jens
- 1 x Multi-Effect Board / Flut/Voc - Bernie

Monitoring:

Ideal: 3 Monitors + 2 In-Ear (Drum / Violin)
Restricted: 3 (2 outputs + 2 In-Ear)
Small Stages: 2 (1 outputs + 2 In-Ear)

Drumset:

Alles bereits installiert und verkabelt:
1x Bassdrum direkt
1x Bassdrum Subbass
1-2x Snare
1x HiHat / Ride
2-3x Tom
1x Overhead
1x Einspieler



Technical Rider (Akustik-Drums small)

Max. channels – mixing console:

1. Lead Vocals (Bernie)
2. Background Vocals (Harry)
3. Background Vocals (Jens)
4. Background Vocals (Linda)
5. Acoustic Guitar
6. Mandoline
7. E-Guitar
8. Violine (Linda)
9. E-Bass
10. Drums Links
11. Drums Rechts
12. Einspieler SamplePad

Vocals/Instruments/Backline:

- 4 x Vocals (2 x Lead, 2 x Background)
- 1 x Semi-Acoustic Guitar – Bernie
- 1 x Mandoline (acoustic with integrated Pickup) – Bernie
- 1 x Flute – Bernie
- 1 x Violine (acoustic with Pickup) - Linda
- 1 x E-Guitar - Harry
- 1 x E-Bass - Jens
- 1 x Drumset - Dario
- 1 x Guitar Combo 2x12 – Harry
- 1 x Multi-Effect Board - Harry
- 1 x Bass Amp (integrated DI) + Box - Jens
- 1 x Multi-Effect Board / Flut/Voc - Bernie



Stereo Out

Monitoring:

Ideal: 3 Monitors + 2 In-Ear (Drum / Violin)
Restricted: 3 (2 outputs + 2 In-Ear)
Small Stages: 2 (1 outputs + 2 In-Ear)

Drumset:

Alles bereits installiert, gemischt und verkabelt:
1x Stereo Out
1x Einspieler

Techn. Contact:

Jens Ohly
jens_ohly@irxn.net
tel: +49 (0) 176 83056768